

The Impact of the Distribution Network Type and Configuration on the Transient Behavior of the Fault and Neutral Points during Earth Faults

M. F. Abdel-Fattah, M. Lehtonen, R. J. Millar, C. J. Kim

Abstract--The main goal of this paper is to investigate the impact of the network type and configuration on the transient behavior of the fault and neutral points during an earth fault. Studying both neutral and fault points enables us to understand clearly the network behavior. The investigations cover the effect of the network type including, feeder types: overhead line and mixed overhead and cable networks with different neutral earthing conditions: unearthed (isolated) or compensated neutral networks. The investigations focused on the transient behavior of the fault point (fault current and voltage) and neutral point voltage. A mathematical simulation model based on a realistic network is implemented using the transient simulation program ATP/EMTP. The effect of the capacitive response of cables in mixed networks has been investigated and presented. On the other hand, the interaction with a compensation coil has been highlighted as well.

Keywords: Medium voltage distribution networks, earth fault transients, neutral point voltage, fault point voltage and current.

I. INTRODUCTION

THE importance of investigating fault generated transients is increasing especially, in high-speed and smart protection systems. According to a previous investigation [1], the network type and configuration have an impact in the transient behavior of the earth fault disturbance; however, a further comprehensive investigation of the transient behavior's dependency on network configuration under different types of neutral connection has yet to be performed and would help us to predict the network transient performance. In Finland, the Nordic and many European countries, the specific conductivity of the soil is usually so low that it is not easy to achieve low earthing resistances in the protective earthing at the distribution substations and in the operational earthing of the low-voltage network; the earthing resistances are typically of the order of a few ohms. This is the main reason why the

medium-voltage network is operated as unearthed (isolated) neutral. Further networks often have compensation of the earth fault current (compensated neutral networks) [2]. The main advantages of unearthed neutral networks are small earth fault currents and that a single fault does not require immediate shutdown of the medium voltage distribution network. The main problem is the over-voltage caused by the charging of the system capacitance of the sound phases and lines, which may lead to flashover/breakdown or may establish a double line to earth fault [3]. The fault and neutral points have a special significance as they can clearly describe the fault characteristics. Direct treatment of this subject is conspicuously lacking in the literature. The fault point investigation is of special concern as it highlights the behavior of the fault voltage and current. Both fault voltage and current behavior can determine how the fault will developed.

In transient arcing faults, at zero-current points, the fault can extinguish permanently or reignite again, as, for example, in intermittent faults, mainly based on the arc voltage (magnitude and its rate of rising) and the arc current magnitude. The nonlinearity of the arcing resistance may have an effect in the transient behavior. The effect of the arc nonlinearity will not be considered in this paper. The arc resistance will be presented simply as a constant ohmic value as proposed by Warrington [4] or Blackburn [5]. Care must be taken, of course, not to use empirical formulae out of context. The isolated or compensated neutral point voltage gives rise to the overvoltage phenomenon, which increases the risk of a double line to earth fault.

In this paper, the impact of the network configuration and type including feeder types (overhead line and mixed overhead and cables) and neutral earthing conditions (isolated or compensated neutral network) will be presented. The investigations will focus on the transient behavior of the fault point (fault current and voltage) and neutral point voltage. Based on a typical 20 kV medium voltage distribution network configuration, a suitable network model will be proposed for the required investigations. The mathematical model of the network will be implemented using EMTP-ATP program [6]. A primary (110/20 kV) substation feeds a rural overhead network consisting of several feeders of many tens of kilometers length and suburban underground network containing several short feeders. The high values of the distributed earth capacitance of the cables in cable or mixed networks may have a strong effect on the transient response of

M. F. Abdel-Fattah (corresponding author) is with the Department of Electrical engineering, School of Science and Technology, Aalto University, 00076 Espoo, Finland (Email: mohamed.abdel-fattah@aalto.fi, Tel: +358-9470-22406, Fax: +358-9470-25012).

M. Lehtonen and R. J. Millar are with the Department of Electrical engineering, School of Science and Technology, Aalto University, Espoo, Finland.

C. J. Kim is with Department of Electrical and Computer Engineering at Howard University, Washington, DC. U.S.A.

the distribution network. Based on the simulation results, practical observations will be presented and should be considered during network planning and operation to achieve the required transient performance of the network.

II. THE STUDY MV NETWORK

Based on present 20 kV medium voltage distribution networks, a realistic network of the arrangement shown in Fig. 1 is proposed for the study. The network data are given in the appendix (data and Fig. 11). A typical arrangement of the rural overhead line and suburban underground cable feeders (at 20 kV) has been proposed based on information from [6-10] and is given in the appendix (Figs. 12, 13). The mathematical model of the network has been implemented using the alternative transient program ATP/EMTP [11], which is a popular simulation software package mainly intended for transient analysis applications. ATPDraw, a graphical pre-processor to ATP, has been used to construct the network elements using suitable graphical blocks/symbols, to plot the required figures and to write the required output data files in a suitable form for transfer to Matlab [12] for any required advanced analysis. The ATPDraw circuit is also given in the appendix (Fig. 14).

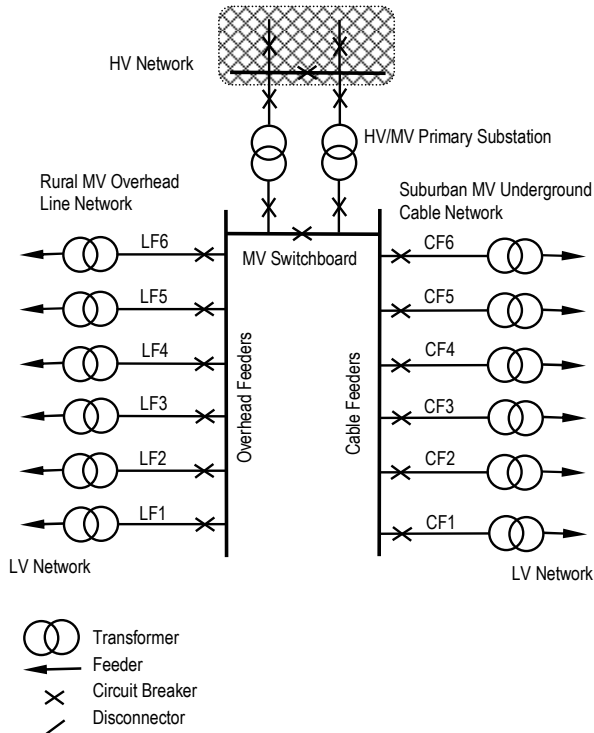

Fig. 1. The realistic arrangement of the medium voltage distribution network.

III. THE TRANSIENT BEHAVIOR OF THE NETWORK

In this section, the transient behavior of the network will be investigated during an earth fault (SLGF: single line to ground fault in phase-a) in the first overhead feeder (LF1) of the rural overhead line network. The investigations will focus on the transient behavior of the fault point for the fault current (IFa)

and voltage (VF_a) and the neutral point voltage (VN). Considering the same fault conditions (type: SLGF, location: on feeder LF1, moment: at 2 ms of the second cycle and fault resistance: 100 Ω), the network transient behavior will be investigated in the following different simulation test cases of network type and configuration:

- Unearthed overhead network (U OH)
- Compensated overhead network (C OH)
- Unearthed mixed network (U Mx)
- Compensated mixed network (C Mx)

From these simulation test cases, the behavior of the network can be investigated easily from the following comparisons:

- A. Comparison between unearthed and different compensation levels of overhead network. This comparison is required when changing the overhead network operation from unearthed operation into compensated neutral operation. It also clarifies the effect of compensation level in the transient behavior of the overhead network.
- B. Comparison between unearthed and different compensation levels of mixed network. This comparison is required when changing the mixed network operation from unearthed operation into compensated neutral operation. It also clarifies the effect of compensation level in the transient behavior of the mixed network.
- C. Comparison between unearthed and compensated overhead and mixed networks. This comparison gives a general picture about different network operation conditions.

In the following sections, suitable figures will present the transient behavior of the network based on the three comparison cases. Each figure includes two sub-figures. The upper sub-figure presents a period of three cycles (60 ms at 50 Hz), which, given that the fault occurs at 22 ms (2 ms in the second cycle), can present the behavior in the first two cycles after the fault incidence. The lower sub-figure focuses only on the transient period (the first three milliseconds after fault incidence) to highlight the behavior during the fast transient period. Each comparison contains three figures. The behavior of the neutral point voltage (VN) is presented in the first figure, the fault point voltage (VF_a) in the second figure and the fault point current (VF_a) in the third figure.

A. Comparison between unearthed and different compensation levels of overhead network

Fig. 2 presents the neutral point voltage (VN) for unearthed (VN Un) and different compensation levels of overhead network. The considered levels of compensation are: 80 % (VN C80%), 90 % (VN C90%), 100 % (VN C100%), 110 % (VN C110%) and 120 % (VN C120%). Fig. 3 presents the fault point voltage (VF_a) for unearthed (VF_aUn) and different compensation levels of overhead network. The considered levels of compensation are: 80 % (VF_aC80%), 90 % (VF_aC90%), 100 % (VF_aC100%), 110 % (VF_aC110%) and

120 % (VNFa120%). Fig. 4 presents the fault point current (IFa) for unearthed (IFaUn) and different compensation levels of overhead network. The same levels of compensation are considered, 80 % (IFaC80%), 90 % (IFaC90%), 100 % (IFaC100%), 110 % (IFaC110%) and 120 % (IFa120%).

B. Comparison between unearthed and different compensation levels of mixed network

Fig. 5 presents the neutral point voltage (VN) for unearthed (VN Un) and different compensation levels of mixed network. The considered levels of compensation are: 80 % (VN C80%), 90 % (VN C90%), 100 % (VN C100%), 110 % (VN C110%) and 120 % (VN C120%). Fig. 6 presents the fault point voltage (VFa) for unearthed (VFaUn) and different compensation levels of overhead network. The considered levels of compensation are: 80 % (VFaC80%), 90 % (VFaC90%), 100 % (VFaC100%), 110 % (VFaC110%) and 120 % (VNFa120%). Fig. 7 presents the fault point current (IFa) for unearthed (IFaUn) and different compensation levels of overhead network. The considered levels of compensation are: 80 % (IFaC80%), 90 % (IFaC90%), 100 % (IFaC100%), 110 % (IFaC110%) and 120 % (IFa120%).

C. Comparison between unearthed and compensated overhead and mixed networks

Fig. 8 presents the neutral point voltage (VN) for unearthed overhead network (VN U OH), compensated neutral overhead network (VN C OH), and unearthed mixed network (VN U Mx), compensated neutral mixed network (VN C Mx). The considered level of compensation is 100 %. Fig. 9 presents the fault point voltage (VFa) for unearthed overhead network (VFaU OH), compensated neutral overhead network (VFaC OH), unearthed mixed network (VFaU Mx), and compensated neutral mixed network (VFaC Mx). Fig. 10 presents the fault point current (IFa) for unearthed overhead network (IFaU OH), compensated neutral overhead network (IFaC OH), unearthed mixed network (IFaU Mx), and compensated neutral mixed network (IFaC Mx).

D. The transient investigations of network behavior

Based on the simulation results presented in Figs. 2-10, the following investigations can be concluded:

It can be seen from Figs. 2-4 that the transient is very similar for the neutral point voltage and fault point voltage and current. Therefore, the compensation of overhead network has almost no effect on the network transient performance. The compensation also has little effect on the steady-state neutral point voltage, however it sharply decreases the steady-state fault point voltage and current. The same behavior can be found in mixed networks based on Figs. 5-7. The transient is similar, in the first two milliseconds, for neutral point voltage and fault point voltage and current. Therefore, compensation of mixed (overhead and cable) network has little effect on the network transient performance. The compensation slowly increases the steady-state neutral point voltage by about 10% with a leading phase shift of about 45°.

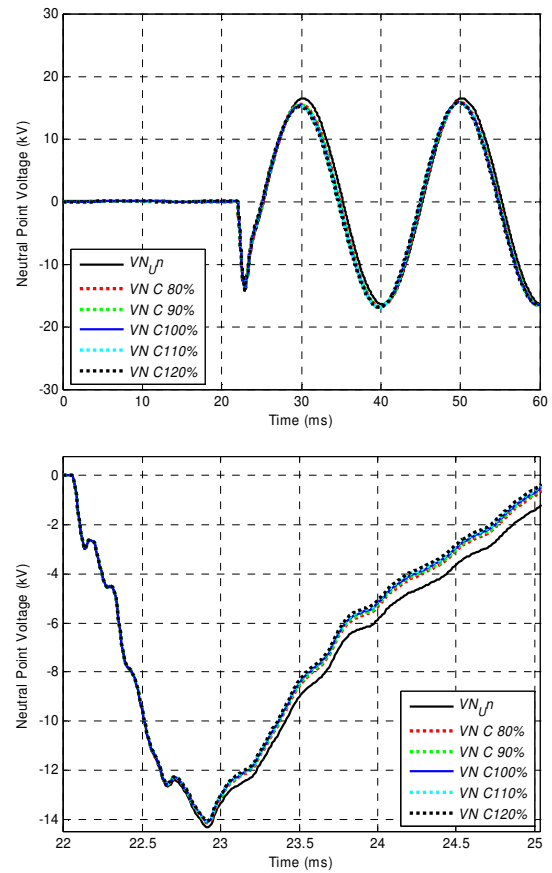

Fig. 2. The neutral voltage for unearthed and compensated overhead network.

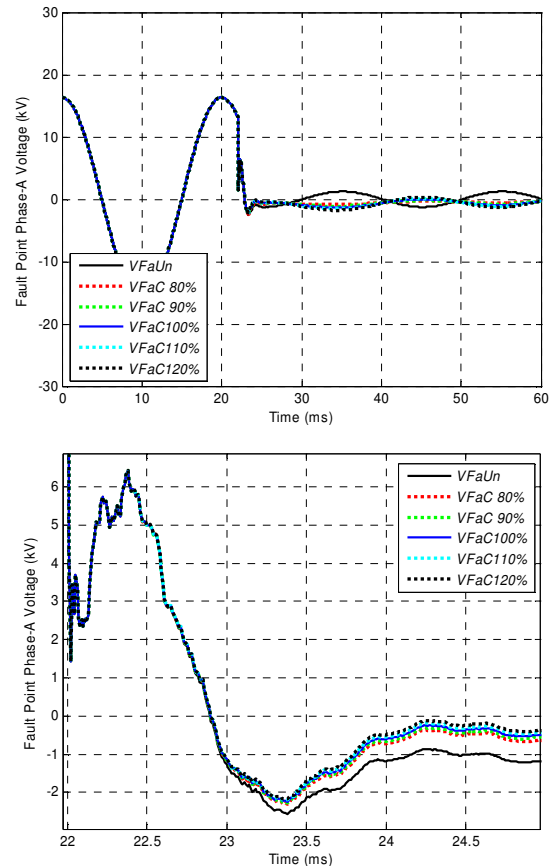

Fig. 3. The fault voltage for unearthed and compensated overhead network.

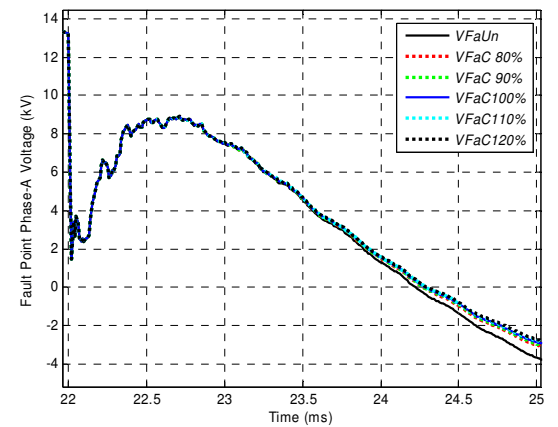
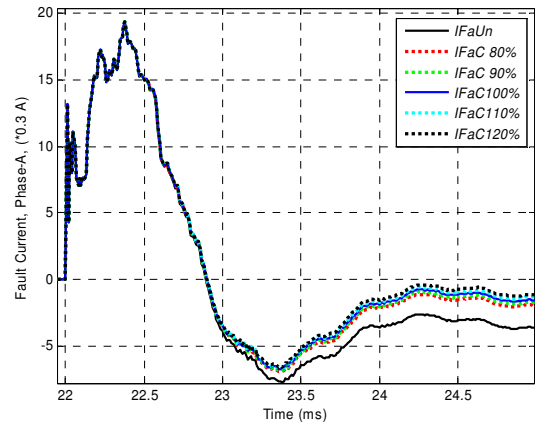
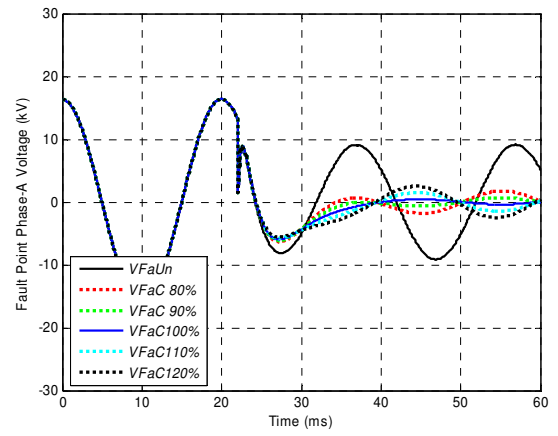
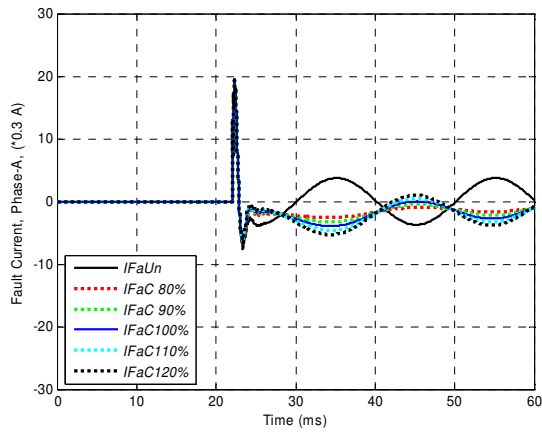

Fig. 4. The fault current for unearthed and compensated overhead network.

Fig. 6. The fault voltage for unearthed and compensated mixed network.

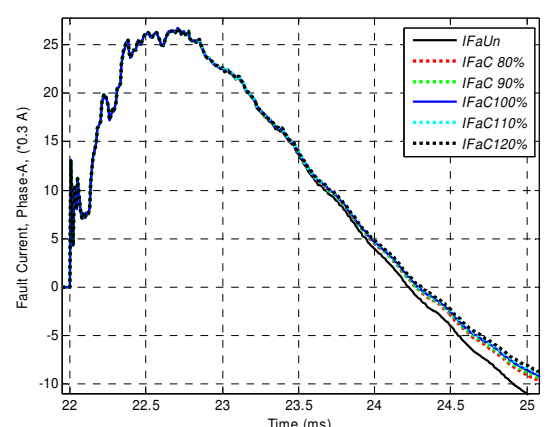
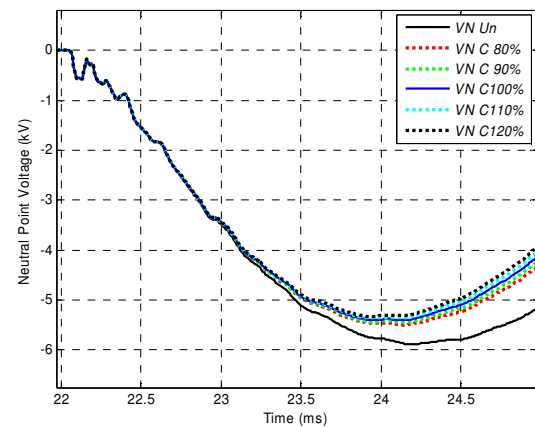
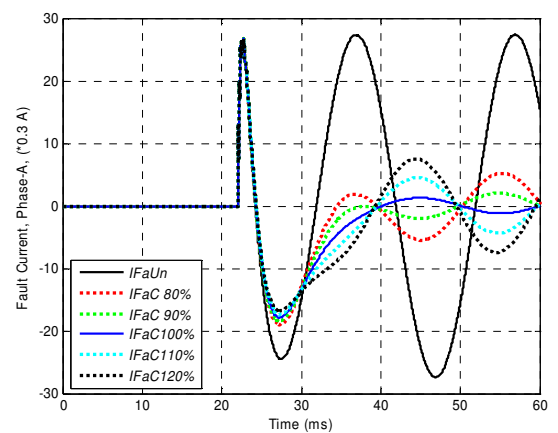
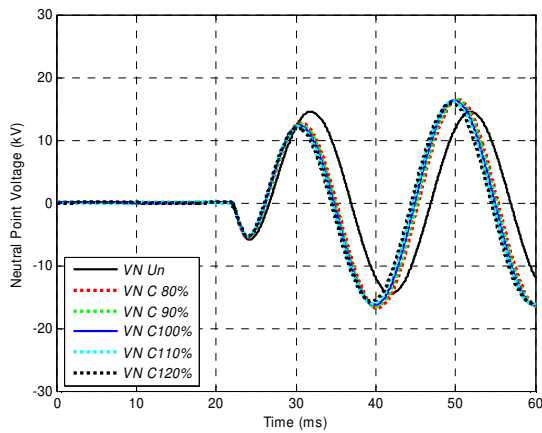

Fig. 5. The neutral voltage for unearthed and compensated mixed network.

Fig. 7. The fault current for unearthed and compensated mixed network.

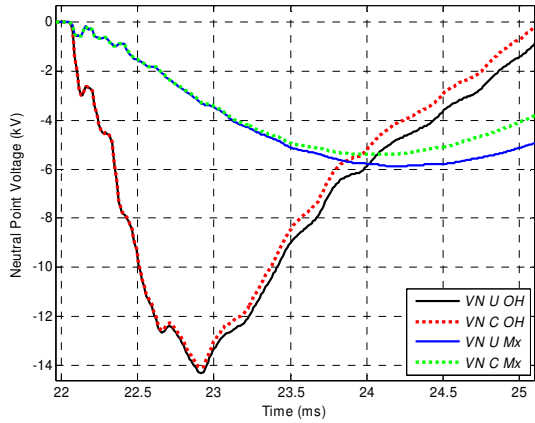
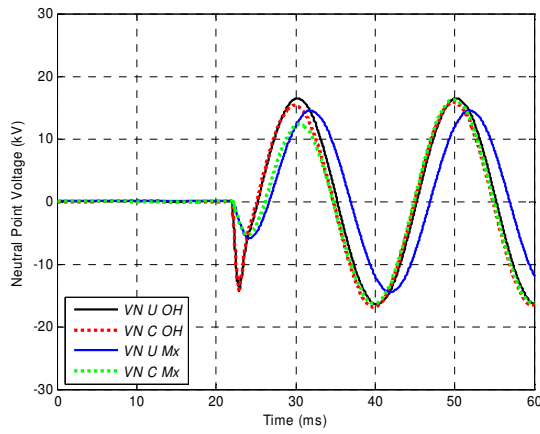

Fig. 8. The neutral voltage for unearthed and compensated networks.

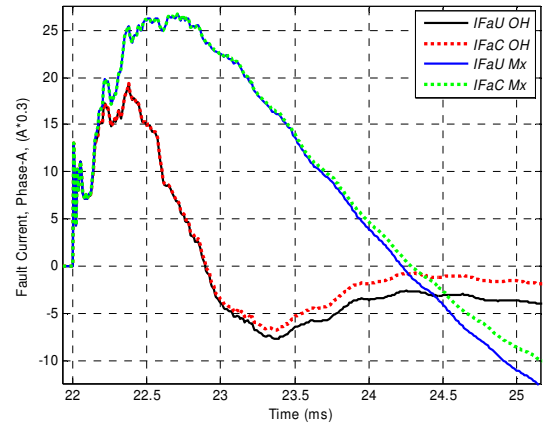
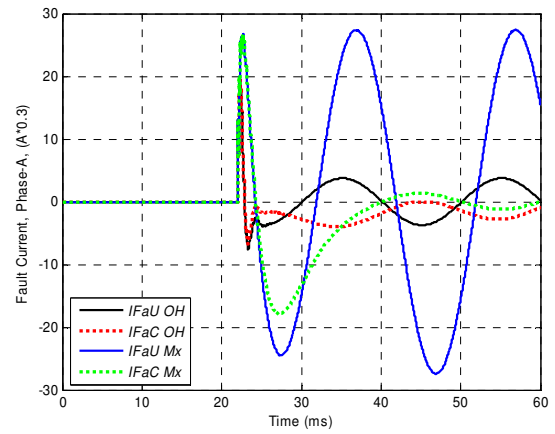

Fig. 10. The fault current for unearthed and compensated networks.

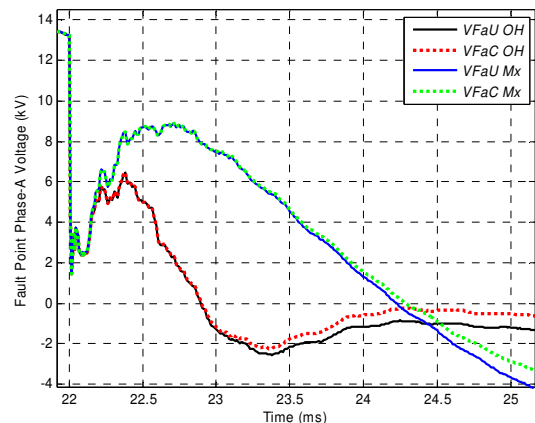
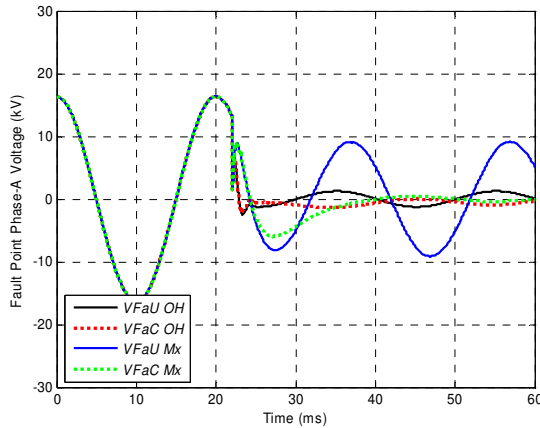

Fig. 9. The fault voltage for unearthed and compensated networks.

On the other hand, the compensation slowly decreases the steady-state fault point voltage and current to very low levels. The slow speed of the transient response behavior is very clear in compensated mixed networks. The compensation level has a meaningful effect on the oscillation damping situation. Over-damping behavior appears with 100% compensation while under-damping behavior appears with other levels of compensation. Figs. 8-10 compare and clarify the transient and steady-state behavior of the networks under different operating conditions. The steady-state component for neutral point voltage is higher, by about 10% in magnitude, for overhead networks regardless of the compensation level (Fig. 7). A similar situation can be found for compensated mixed network, which smoothly and slowly changes (Fig. 7). The steady-state components for fault point voltage and current are very high in mixed networks. The highest value can be found in the case of unearthed mixed network, which should be controlled and limited by a suitable compensation degree (Figs. 9-10).

Regarding the transient behavior, the rate-of-change in the neutral point voltage, in the transient period, is higher in overhead network regardless of the compensation level and lower in mixed network regardless of the compensation level (Fig. 7). The opposite response can be observed for the transient behavior of the fault point voltage and current (Figs. 9-10). The higher magnitudes of fault point voltage and current in mixed networks affect its response. It sharply increases its rate-of-change. Although the over/under damping

phenomenon is expected in mixed network based on previous investigations, we found a higher rate-of-change in transients. The compensation levels have no effect in the transient rate-of-change (Figs. 9-10). The higher capacitive effect is dominant in mixed networks and the effect of the compensation coil appears very slowly, within about 10 ms.

IV. CONCLUSIONS

In this paper, the transient behavior of the medium voltage distribution network has been highlighted. The effect of network type and operation on the transient behavior of the neutral point voltage and fault point voltage and current has been investigated based on simulation results from many simulation test cases of a mathematical model depicting a realistic network using the ATP/EMTP transient simulation program. Many important observations about network transient behavior have been presented. The fast transients of the neutral point voltage are higher in overhead networks regardless of their compensation level. On the other hand, the fast transients of fault point voltage and current is higher in mixed networks regardless its compensation level. The transient period features are mainly controlled by the higher capacitive effect of the cables in mixed networks. The compensation coil effect appears slowly within 10 ms, and only affects the steady state components. These observations should be considered when planning to change the network operation from one condition to another to achieve the required network performance.

V. APPENDIX

The distribution network data:

HV/LV primary substation:

Substation transformers: 2×40 MVA

110/20 kV, Connection: Star/Delta (Y/ Δ)

Reactance = 0.10 pu

MV network total load = 36 MVA

Rural MV overhead line network:

Total load = 6 MVA

Total feeders' length = 180 km

Feeders = 6×30 km (feeder total length)

Feeders' load = 6×900 kVA = 5400 kVA (total load, PF = 0.9 Leading)

LV transformers (20/0.4 kV) = 6×1000 kVA = 6 MVA

Connection: Delta/Star-Earthen (Δ/Y_{\square})

Feeder sections details:

Feeder sections' length = 5×2 km + 8×1 km + 8×1.5 km = 30 km

Feeder sections' load = 8×90 kVA + 3×45 kVA + 2×22.5 kVA = 900 kVA

LV transformers = 8×100 kVA + 3×50 kVA + 2×25 kVA = 1000 kVA

Suburban MV underground cable network:

Total load = 30 MVA

Total feeders' length = 18 km

Feeders = 6×3 km (feeder total length)

Feeders' load = 6×4500 kVA (total load, PF = 0.7 -improved to- 0.9)

Power factor improved from 0.7 to 0.9 by capacitor bank units

LV transformers (20/0.4 kV) = 6×5000 kVA = 30 MVA

Connection: Delta/Star-Earthen (Δ/Y_{\square})

Feeder sections details:

Feeder sections length = 4×600 m + 6×100 m = 3 km

Feeder sections' load = 4×900 kVA + 5×180 kVA = 4500 kVA

LV transformers = 4×1000 kVA + 5×200 kVA = 5000 kVA

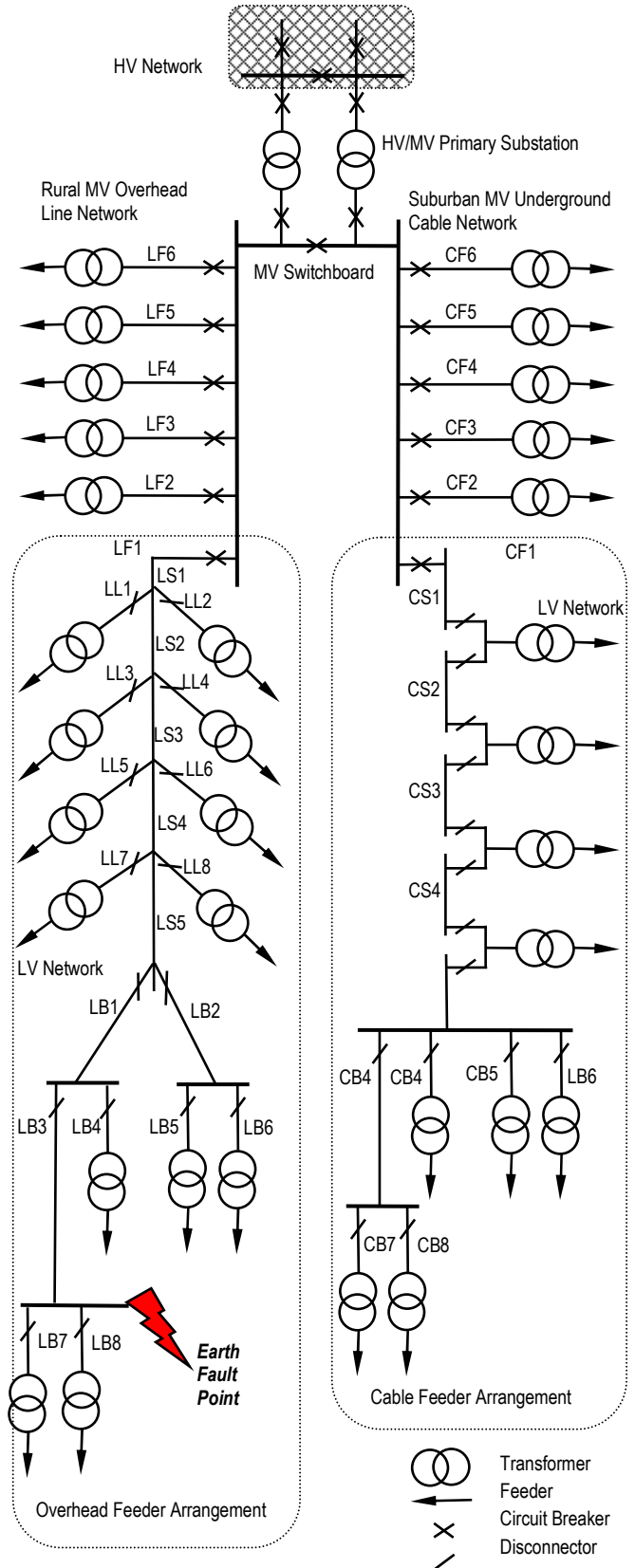

Fig. 11. The arrangement of the medium voltage distribution network.

Rural 20 kV Overhead Lines
MV wooden pole with steel crossarm

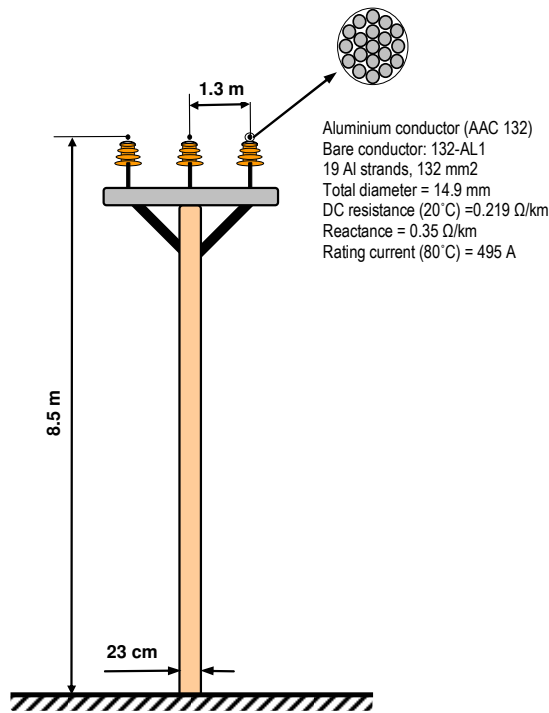
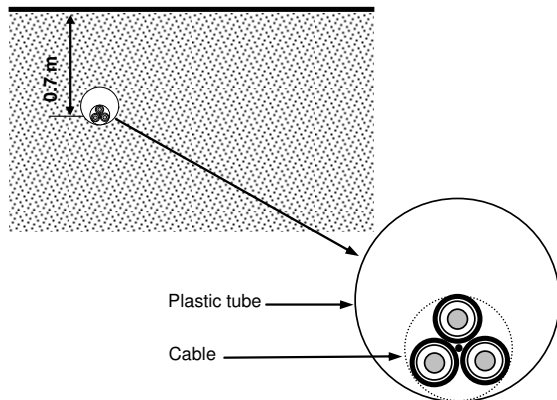

Fig. 12. A typical arrangement for 20 kV rural overhead line feeders.

Suburban 20 kV Underground Cables



AHXAMK-W 3x185Al+35 Cu 20 kV
Conductor diameter = 15.7 mm
Sheath diameter = 37 mm
Cable diameter = 80 mm
Max DC resistance of phase conductor (20°C) = 0.164 Ω/km
Max DC resistance of centre conductor (20°C) = 0.524 Ω/km
AC resistance of phase conductor (65°C) = 0.20 Ω/km
AC resistance of phase conductor (90°C) = 0.21 Ω/km
Inductance = 0.36 mH/km
Operating capacitance = 0.26 μF/km
Charging current (at 20 kV) = 1.00 A/km
Earth fault current (at 20 kV) = 2.90 A/km
Rating current (65°C) = 330 A

Fig. 13. Typical arrangement of 20 kV suburban underground cable feeders.

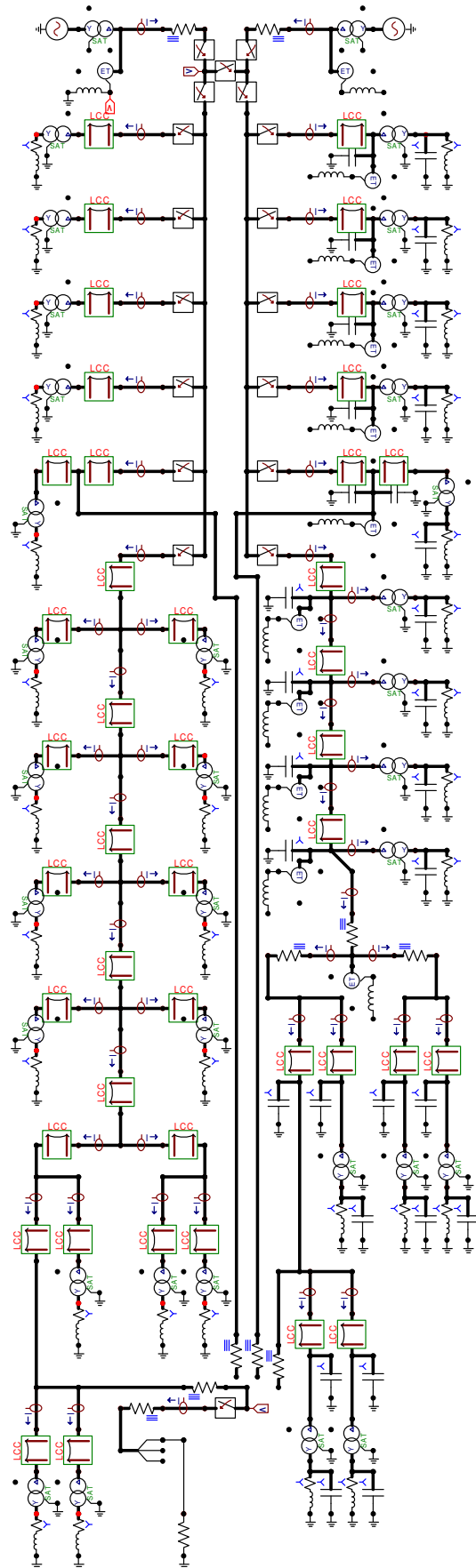

Fig. 14. The ATPDraw circuit of the study network.

VI. REFERENCES

- [1] M. F. Abdel-Fattah and M. Lehtonen, "EMTP-ATP Investigations of Earth-Fault Transient Simulation in Realistic Finnish 21 kV Overhead Line Medium Voltage Network," EEUG Meeting 2009: European EMTP-ATP Conference, Delft, The Netherlands, October, 2009.
- [2] L. Kumpulainen et al., "Distribution network 2030, Vision of the future power system," Technical Research Centre of Finland (VTT), Research Report VTT-R-03835-07, Espoo, Finland, May 2007.
- [3] M. Lehtonen and T. Hakola, *Neutral Earthing and Power System Protection - Earthing Solutions and Protective Relaying in Medium Voltage Distribution Networks*, Vassa, Finland: ABB Transmit Oy, FIN-65101, 1996.
- [4] A. R. Warrington, "Application of the ohm and mho principles to protective relays," *Transactions of the American Institute of Electrical Engineers*, vol. 65, iss. 6, pp. 378-386, Jun. 1946.
- [5] J. L. Blackburn and T. J. Domin, *Protective relaying principles and applications*, Third Edition, Taylor & Francis Group, LLC, Boca Raton, USA, 2007.
- [6] E. Lakervi and E. J. Holmes, *Electricity Distribution Network Design*, Second Edition, Peter Peregrinus Ltd. - on behalf of - the Institute of Electrical Engineers, London, U.K., 1995.
- [7] J. Elovaara and Y. Laiho, *Sähkölaitostekniikan Perusteet*, Tekijät ja Otatieto Oy, Karisto Oy, Hämeenlinna, Finland, 1993.
- [8] Prysmian Cables & Systems Finland. Information on: <http://www.prysmian.fi/index.html>
- [9] E. Lakervi and J. Partanen, *Sähköjälkelutekniikka*, Gaudeamus Helsinki University Press / Otatieto, Helsinki, Finland, 2008.
- [10] M. Hyvärinen, *Electrical networks and economies of load density*, TKK Dissertations 146, Espoo, Finland, 2008.
- [11] Information at: <http://www.emtp.org/>
- [12] Information at: <http://www.mathworks.com/>

VII. BIOGRAPHIES



Mohamed F. Abdel-Fattah was born in Qualiobia, Egypt on June 11, 1972. He received his B.Sc. in 1995 with distinction and first class honors from Zagazig University, Egypt and was appointed as a teaching assistant and researcher with the Faculty of Engineering. From the same university, he received his M.Sc. degree in 2000 and Ph.D. degree in 2006 and was appointed as a lecturer with the Department of Electrical Power and Machines Engineering. He is a member of IEEE and IET. Recently, he joined Aalto University, Finland, as a post-doctoral researcher with the power systems group in the Department of Electrical Engineering, School of Science and Technology. His main activities include power system protection; earth-fault detection, diagnosis and location in medium and high-voltage networks. His current research topic is to develop the smart/wide-area protective schemes to diagnose the unconventional hidden faults using transient and fast transient-based algorithms. (e-mail: mohamed.abdel-fattah@aalto.fi, mohamed.f.abdelfattah@gmail.com).



Matti Lehtonen (1959) was with VTT Energy, Espoo, Finland from 1987 to 2003, and since 1999 has been a professor at the Helsinki University of Technology (TKK), where he is now head of Power Systems and High Voltage Engineering.

Matti Lehtonen received both his Master's and Licentiate degrees in Electrical Engineering from Helsinki University of Technology in 1984 and 1989, respectively, and the Doctor of Technology degree from Tampere University of Technology in 1992.

His main activities include power system planning and asset management, power system protection including earth fault problems, harmonic related issues and applications of information technology in distribution systems (e-mail: matti.lehtonen@tkk.fi).



and the rating of power cables. (Tel. +358 9 470 25042, E-mail: john.millar@aalto.fi)

R. John Millar was born in Wairoa, New Zealand (1963) and received a Bachelor of Engineering Degree (mechanical) from the University of Auckland in 1984. John Millar completed a Master's Degree in Electrical Engineering in 2002 and a doctorate in 2006 at the Helsinki University of Technology, Finland, which has now become the Aalto University School of Science and Technology. He is now working there as a researcher in the Department of Electrical Engineering and his main fields of interest are distribution network planning

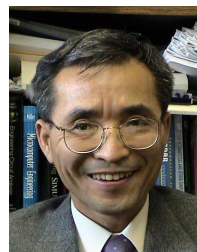

systems in power, aerospace, and nuclear industries.

Charles Kim (M'90, SM'06) received a Ph.D. degree in electrical engineering from Texas A&M University (College Station, TX) in 1989. Since, 1999, he has been with the Department of Electrical and Computer Engineering at Howard University. Previously, Dr. Kim held teaching and research positions at Texas A&M University and the University of Suwon. Dr. Kim's research interests include failure detection, anticipation, and prevention in safety critical electrical/electronic